

付属アダプターリング

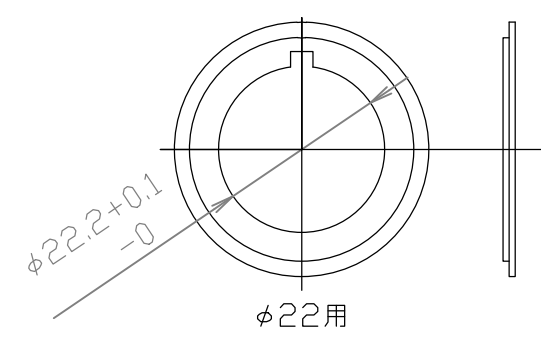

C3604 t=1.6 Niメッキ仕上げ

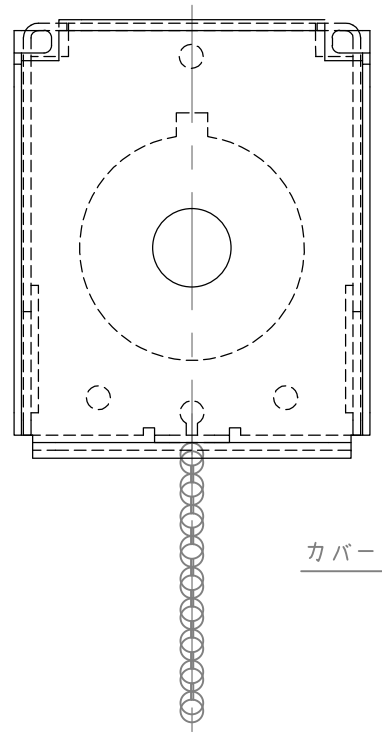
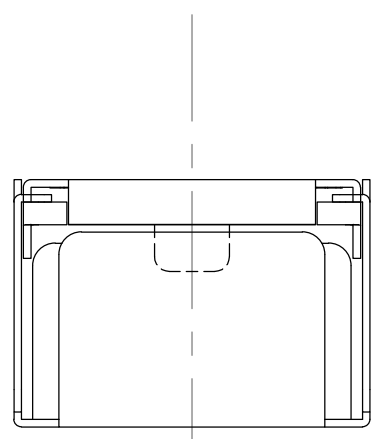

カバー SUS304-2B (塗装無し)
材厚=1.0

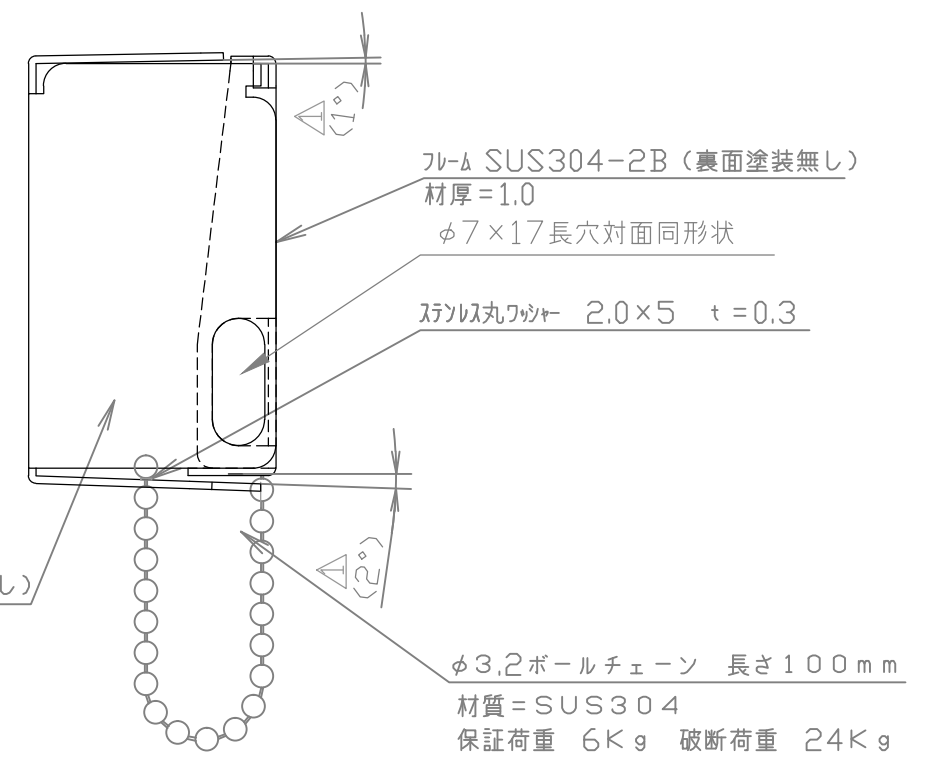
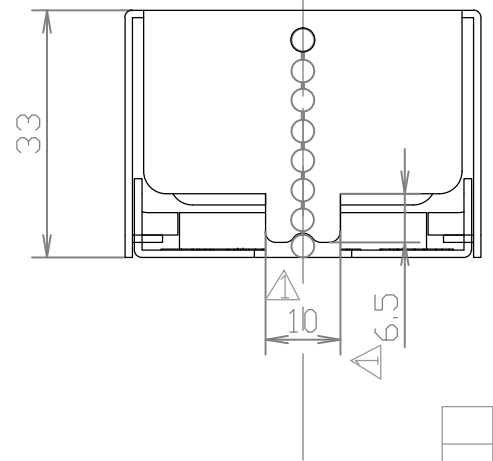

注記

1. $\phi 30$ 用 ボタン径 $\phi 45$ 対応
2. フレーム塗装(黄)日本ペイント オルガネオ「B25-80W」
3. 文字 パッド黒印刷
4. 指示無き寸法公差はJIS B 0408 表1B級 表2B級とする。



Δ 修正	2018-4/17	MK
DESCRIPTION	CHECKED DATE	APPROVED

ITEM	DESCRIPTION	MATERIAL	FINISH	QTY	NOTE
UNLESS OTHERWISE SPECIFIED DIMENSIONS ARE IN MILLIMETER TOLERANCES ON DIMENSIONS± ANGLES± PROJECTION IS TRIGONOMETRY DO NOT SCALE DRAWING					
DRAWING No. Y-61007A03-1			PMD-RC2-D30ADP仕様図		
SCALE 1/1					
DRAWN MKITAHARA 2017-06/26		APPROVED H.SHINDHIRA 2017-06/26			